

PP20 MALE "RED HEAD" VALVE SERVICE KIT

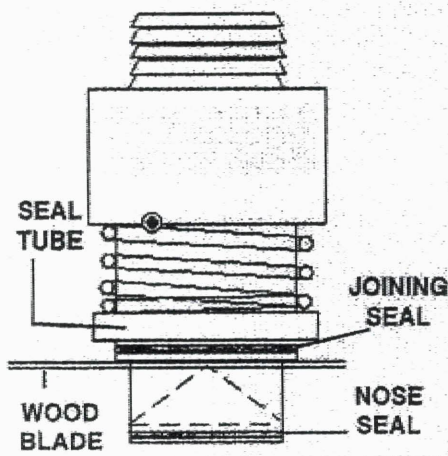

SERVICE KIT CONTENTS:

1 ea. Nose Seal: One of two seals creating the liquid seal. O'ring measures .103" cross sections special material compound – **DO NOT SUBSTITUTE.**

2 ea. Joining Seal: Seals valve probe to car mounted receiver. O'ring measures .070" cross section. Special material compound – **DO NOT SUBSTITUTE.**

1 ea. Seal Lubricant: ¼ ounce.

1 ea. Wood Blade: Holds valve open.

Info only – "L" Teflon Seal and O'ring: Special teflon seal and o'ring combination is one of two seals producing the liquid seal. This seal combination is installed with special tools at the factory and is visible only when valve is completely disassembled. **FIELD REPAIR IS NOT RECOMMENDED.** Contact Red Head Valves™ if replacement is necessary.

INSTALLATION PROCEDURE

1. To open valve, slide red sequence tube ½" back into black cover and hold (this releases seal tube).
2. Simultaneously slide red sequence tube and now revealed seal tube into black cover (flow passage now revealed).
3. Place enclosed wood blade across cone-shaped deflector, release seal tube slowly letting it rest on wood blade. Red sequence tube may also be released at this time (valve should now be held open).
4. Remove nose seal at this time using thin feeler gauge. **CARE MUST BE TAKEN – DO NOT DAMAGE O'RING GROOVE.**
5. Apply thin layer (film sufficient) of seal lubricant to replacement nose seal.
6. Install nose seal: Carefully stretch o'ring allowing it to seat in groove. Do not roll o'ring into groove – rolled or twisted o'ring may cause improper seal.
7. Remove wood blade – **VALVE SHOULD SNAP CLOSED.** If valve does not close rapidly and seal, lubricate inner surfaces of valve with fuel. **CAUTION: FUEL IS HIGHLY FLAMMABLE.** Repeat closing process. If proper rate of closing is not accomplished, contact Red Head Valves™. Improper rate of closing may cause fuel spillage. **DO NOT USE.**
8. Using closing procedure allow valve to slowly close. Ensure seal tube seals on nose seal and red sequence tube snaps forward.
9. Slide red sequence tube back and replace joining seal. Apply thin film of lubricant to o'ring. Use procedure #6 to install joining seal.
10. Repeat closing sequence to ensure proper valve operation.
11. With valve closed and in upright position, fill with fuel and observe if proper seal occurs.
CAUTION: FUEL IS HIGHLY FLAMMABLE.

BEFORE USE OF VALVE, READ ATTACHED NOTICE.

For factory service or technical support contact:

RED HEAD VALVES™ by MTM, Inc. **PH: (918) 824-3700 FAX: (918) 824-3710**